

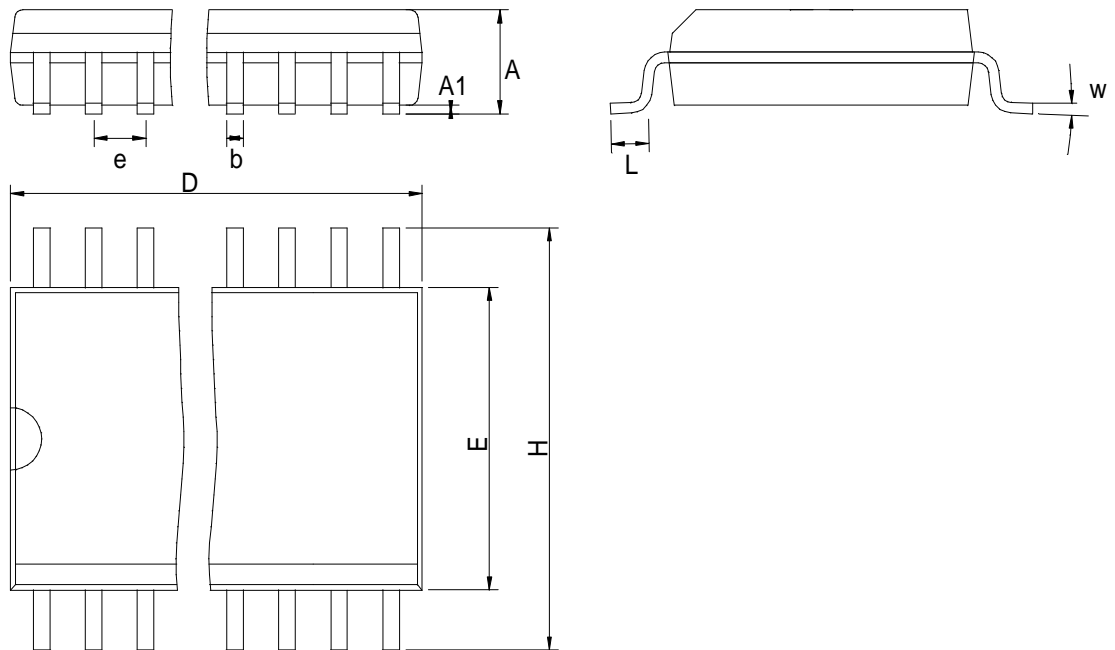

Package Catalogue



Small Outline Package (SOP)

SOP 08 L, 14 L, 16 Ln 150 mil - Jedec MS-012

SOP 18 L, 20 L, 28 L 300 mil - Jedec MS-013

Package type		D	E	H	A	A1	e	b	L	Copl.	w
SOP 08 L	nom max	4,90	3,90	6,00	1,75	0,15	1,27	0,41	0,72	0,10	4°
SOP 14 L	nom max	8,65	3,90	6,00	1,75	0,15	1,27	0,41	0,72	0,10	4°
SOP 16 Ln	nom max	9,90	3,90	6,00	1,75	0,15	1,27	0,41	0,72	0,10	4°
SOP 18 L	nom max	11,58	7,49	10,31	2,54	0,20	1,27	0,41	0,76	0,10	4°
SOP 20 L	nom	12,80	7,49	10,31	2,54	0,20	1,27	0,41	0,76	0,10	4°
SOP 28 L	nom max	17,90	7,49	10,31	2,54	0,20	1,27	0,41	0,76	0,10	4°

Dimension: mm



Package Catalogue

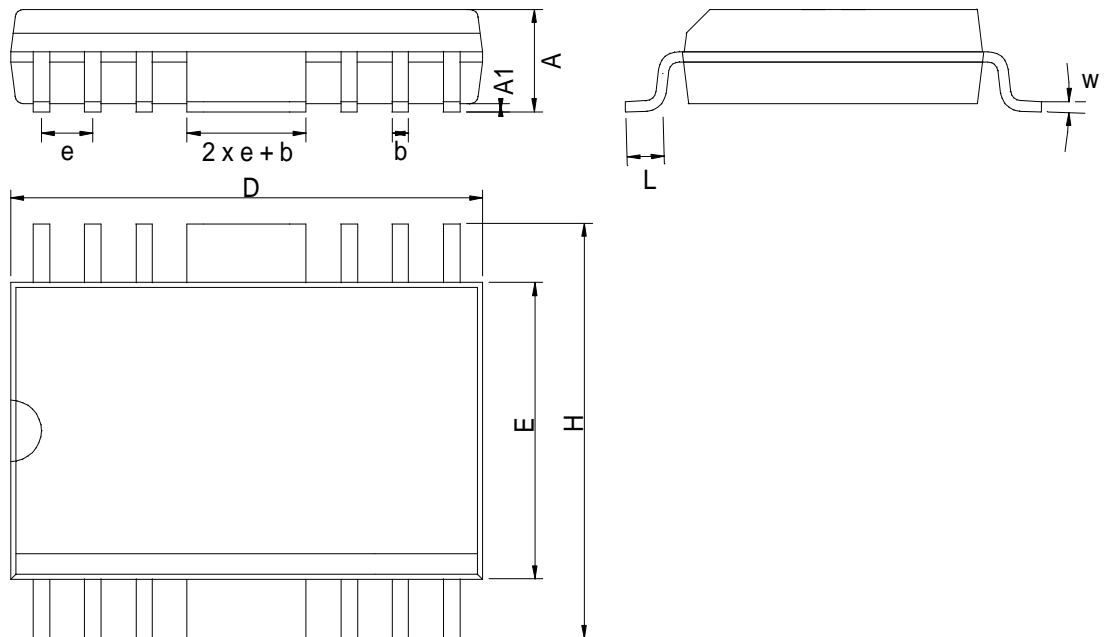

Small Outline Package (SOP)											
SOP 12LP		300 mil									
Package type		D	E	H	A	A1	e	b	L	Copl.	w
SOP 12LP	nom max	11,58	7,49	10,31	2,54	0,20	1,27	0,41	0,76	0,10	4°
Dimension: mm											



Package Catalogue

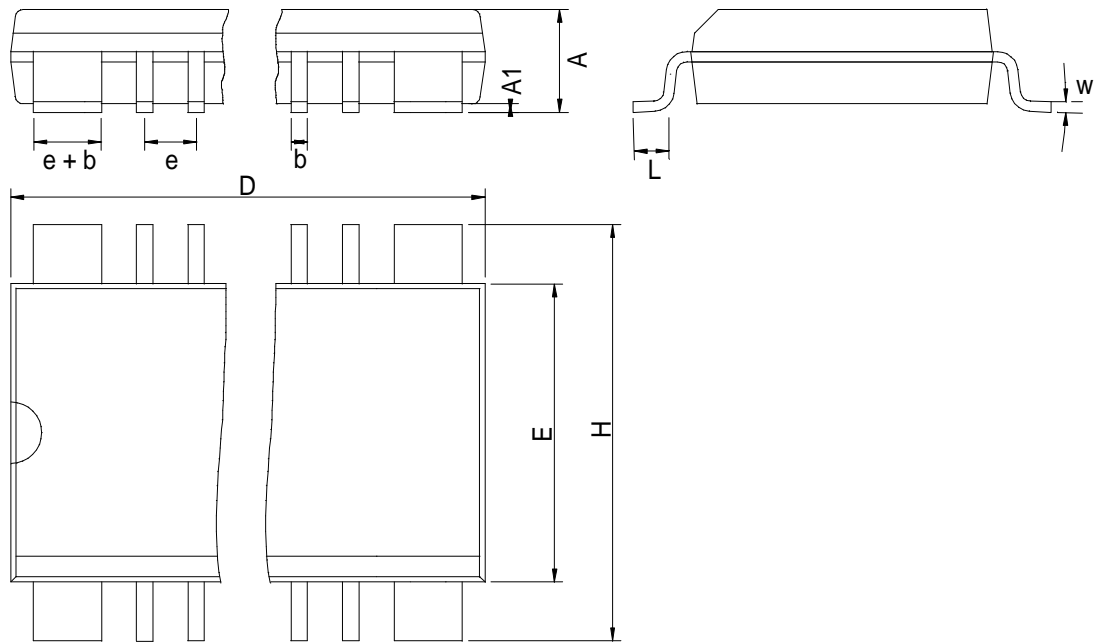

Small Outline Package (SOP)											
SOP 10LP, 20LP 300 mil											
Package type		D	E	H	A	A1	e	b	L	Copl.	w
SOP 10LP	nom max	11,58	7,49	10,31	2,54	0,20	1,27	0,41	0,76	0,10	4°
SOP 20LP	nom max	17,90	7,49	10,31	2,54	0,20	1,27	0,41	0,76	0,10	4°
Dimension: mm											



Package Catalogue

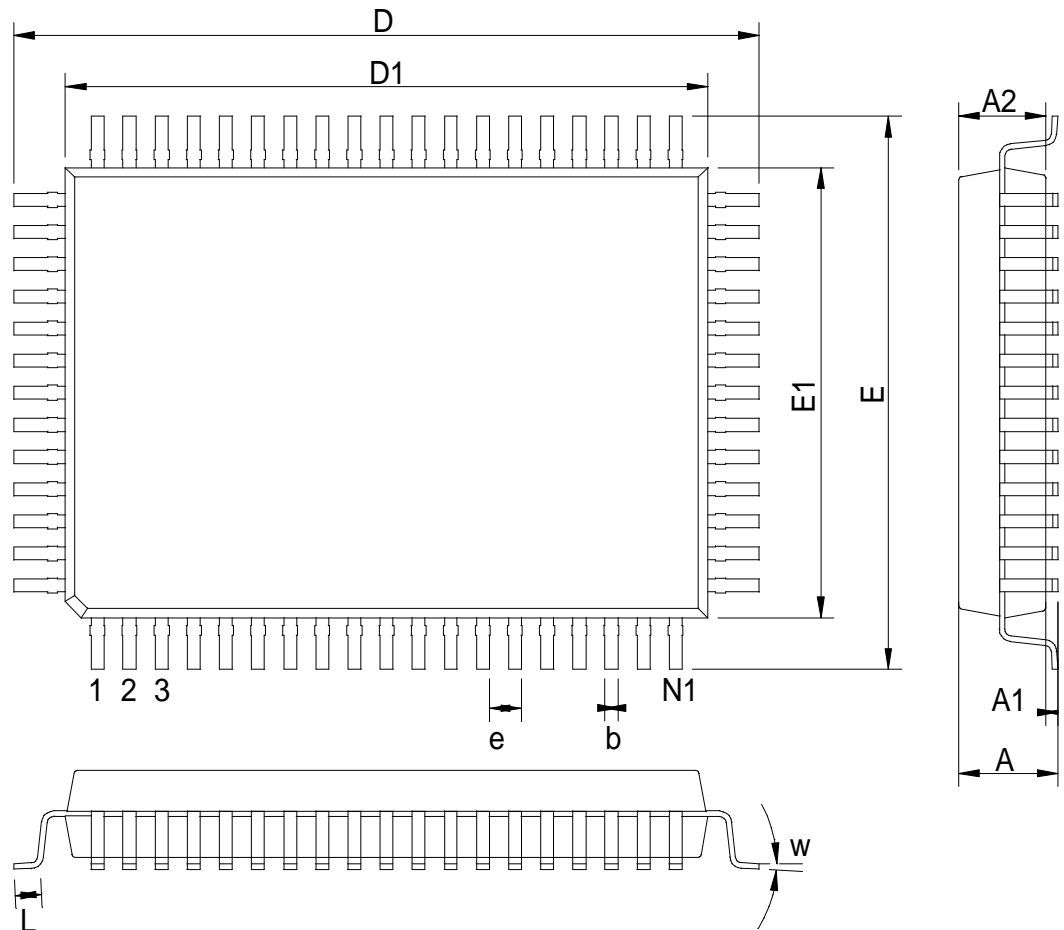

Plast Quad Flat Package (PQFP)		JEDEC	MS-022											
PQFP 64, 80, 100, 128 (Body: 14 x 20)														
Package type		N1	D	D1	E	E1	A	A1	A2	e	b	L	Copl.	w
PQFP 64	nom max	19	23,20	20,00	17,20	14,00	3,08	0,38	2,70	1,00	0,42	0,88	0,10	3°
PQFP 80	nom max	24	23,20	20,00	17,20	14,00	3,08	0,38	2,70	0,80	0,37	0,88	0,10	3°
PQFP 100	nom max	30	23,20	20,00	17,20	14,00	3,08	0,38	2,70	0,65	0,31	0,88	0,10	3°
PQFP 128	nom max	38	23,20	20,00	17,20	14,00	3,08	0,38	2,70	0,50	0,21	0,88	0,10	3°

Dimension: mm



Package Catalogue

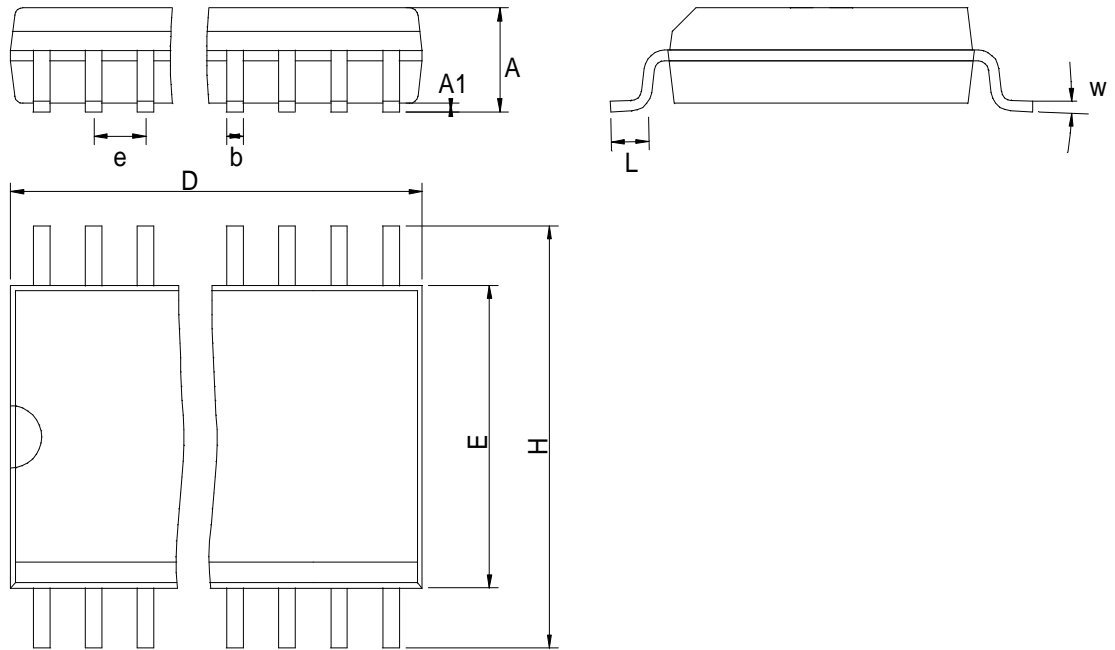

Shrink Small Outline Package (SSOP) - Jedec MO-137
SSOP 14, SSOP 16, SSOP 18, SSOP 20, SSOP 24, SSOP 28

Package type		D	E	H	A	A1	e	b	L	Copl.	w
SSOP 14	nom max	4,90	3,90	6,00	1,75	0,15	0,635	0,26	0,72	0,10	4°
SSOP 16	nom max	4,90	3,90	6,00	1,75	0,15	0,635	0,26	0,72	0,10	4°
SSOP 18	nom max	8,65	3,90	6,00	1,75	0,15	0,635	0,26	0,72	0,10	4°
SSOP 20	nom max	8,65	3,90	6,00	1,75	0,15	0,635	0,26	0,72	0,10	4°
SSOP 24	nom max	8,65	3,90	6,00	1,75	0,15	0,635	0,26	0,72	0,10	4°
SSOP 28	nom max	9,90	3,90	6,00	1,75	0,15	0,635	0,26	0,72	0,10	4°

Dimension: mm